

1. Dodder is a creeping vine that is parasitic on other plants. Which characteristic does dodder share with all other heterotrophs?

- A) It produces nutrients by photosynthesis.
- B) It must grow in bright locations.
- C) It consumes preformed organic molecules.
- D) It remains in one place for its entire life.

2. Which statement best describes animals that are heterotrophs?

- A) They are able to convert light energy into useful chemical bond energy.
- B) They are able to synthesize organic materials from inorganic raw materials.
- C) They are unable to consume preformed organic compounds.
- D) They are unable to synthesize organic materials from inorganic raw materials.

3. Base your answer to the following question on the diagram below, which represents some metabolic activities in a chloroplast, and on your knowledge of biology.

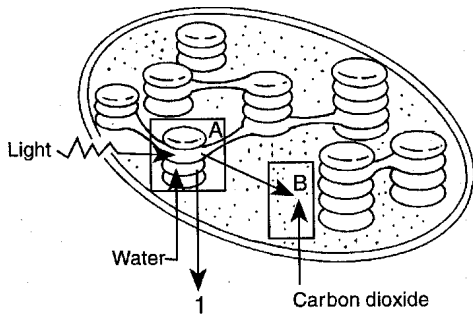

Which substance diffuses in the direction of arrow 1 after it is formed in the structure represented in area A?

- A) carbon dioxide
- B) glucose
- C) oxygen
- D) starch

4. During the process of photosynthesis, energy from the Sun is converted into

- A) chemical energy in the bonds of inorganic molecules
- B) chemical energy in the bonds of organic molecules
- C) enzymes used to produce inorganic molecules
- D) enzymes used to produce organic molecules

5. An experimental setup is shown below.

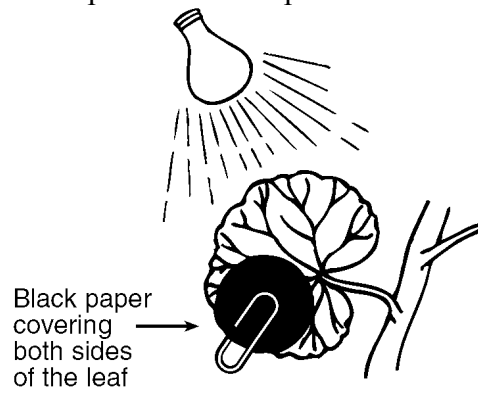

Which hypothesis would most likely be tested using this setup?

- A) Light is needed for the process of reproduction.
 - B) Glucose is not synthesized by plants in the dark.
 - C) Protein synthesis takes place in leaves.
 - D) Plants need fertilizers for proper growth.
6. Leaves of green plants contain openings known as stomates, which are opened and closed by specialized cells allowing for gas exchange between the leaf and the outside environment. Which phrase best represents the net flow of gases involved in photosynthesis into and out of the leaf through these openings on a sunny day?
- A) carbon dioxide moves in; oxygen moves out
 - B) carbon dioxide and oxygen move in; ozone moves out
 - C) oxygen moves in; nitrogen moves out
 - D) water and ozone move in; carbon dioxide moves out

7. The diagram below represents a change in guard cells that open and close pores in a plant.

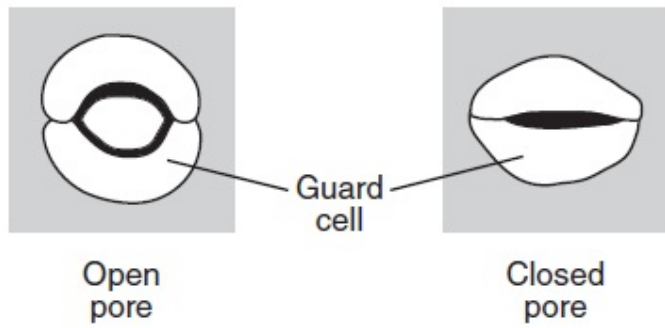

This change directly helps to

- A) increase heterotrophic nutrition
 B) absorb minerals
 C) regulate water loss
 D) reduce seed production
8. The presence of which organelles would identify a cell as a plant cell?
 A) nuclei B) lysosomes
 C) chloroplasts D) cilia
9. A green plant is kept in a brightly lit area for 48 hours. What will *most likely* occur if the light intensity is reduced slightly during the next 48 hours?
 A) Photosynthesis will stop completely.
 B) The rate at which nitrogen is used by the plant will increase.
 C) The rate at which oxygen is released from the plant will decrease.
 D) Glucose production inside each plant cell will increase.
10. Which process is an outcome of photosynthesis?
 A) Complex molecules are broken down to form simple molecules.
 B) Water is absorbed into the root hairs.
 C) Light energy is converted into chemical energy.
 D) Water is transported through vascular tissue.

11. The diagram below represents events associated with a biochemical process that occurs in some organisms.

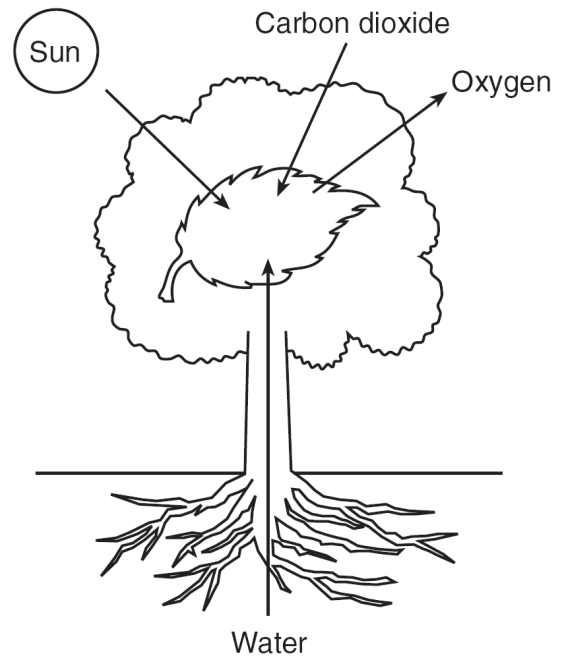

Which statement concerning this process is correct?

- A) The process represented is respiration and the primary source of energy for the process is the Sun.
 B) The process represented is photosynthesis and the primary source of energy for the process is the Sun.
 C) This process converts energy in organic compounds into solar energy which is released into the atmosphere.
 D) This process uses solar energy to convert oxygen into carbon dioxide.
12. A chewing insect damages the vascular tissue of a plant stem. This damage will most directly affect the
 A) excretion of carbon dioxide by root cells
 B) conduction of water and minerals between the roots and leaves
 C) synthesis of auxins in the roots
 D) diffusion of oxygen between root epidermal cells
13. In the leaf of a plant, guard cells help to
 A) destroy atmospheric pollutants when they enter the plant
 B) regulate oxygen and carbon dioxide levels
 C) transport excess glucose to the roots
 D) block harmful ultraviolet rays that can disrupt chlorophyll production

14. Which process directly results in energy being stored in ATP molecules?

- A) cellular respiration
- B) cellular reproduction
- C) diffusion
- D) digestion

Base your answers to questions 15 and 16 on the diagram below and on your knowledge of biology. The diagram represents some processes occurring in the leaf of a plant.

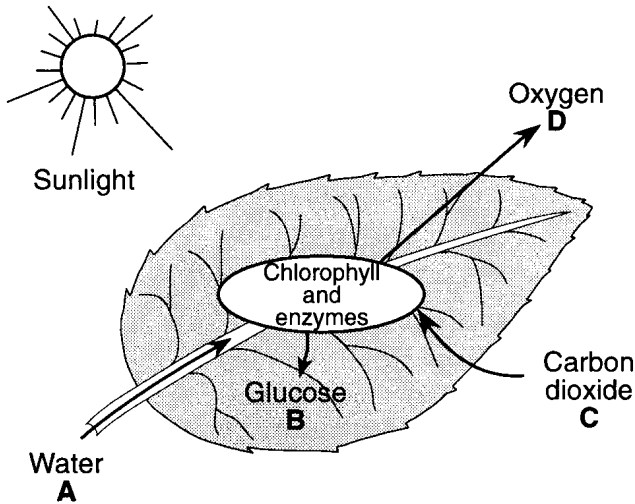

15. Which equation illustrates a process of nutrition carried out within the leaf?

- A) $B + D \rightarrow A + C$
- B) $A + C \rightarrow A + B + D$
- C) $B + C \rightarrow A + D$
- D) $A + B + D \rightarrow B + C$

16. Which letters indicate substances needed by the leaf to carry out the process of aerobic cellular respiration?

- A) A and C
- B) B and C
- C) C and D
- D) B and D

17. In the diagram of a cell shown below, which number indicates the structure in which most of the enzymes involved in aerobic cellular respiration function?

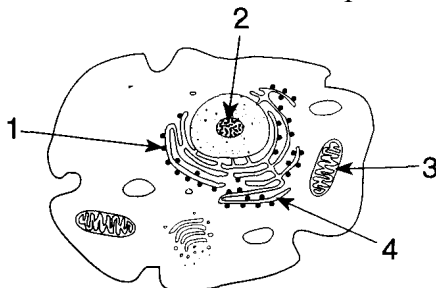

- A) 1
- B) 2
- C) 3
- D) 4

18. Living organisms must be able to obtain materials, change the materials into new forms, remove poisons, and move needed material from one place to another. Many of these activities directly require

- A) energy released from ATP
- B) carbohydrates formed from receptor molecules
- C) the synthesis of DNA
- D) the breakdown of energy-rich inorganic molecules

19. Which two organ systems provide materials required for the human body to produce ATP?

- A) reproductive and excretory
- B) digestive and respiratory
- C) respiratory and immune
- D) digestive and reproductive

20. Base your answer to the following question on the diagrams below and on your knowledge of biology. The arrow below each lettered process indicates where the process takes place.

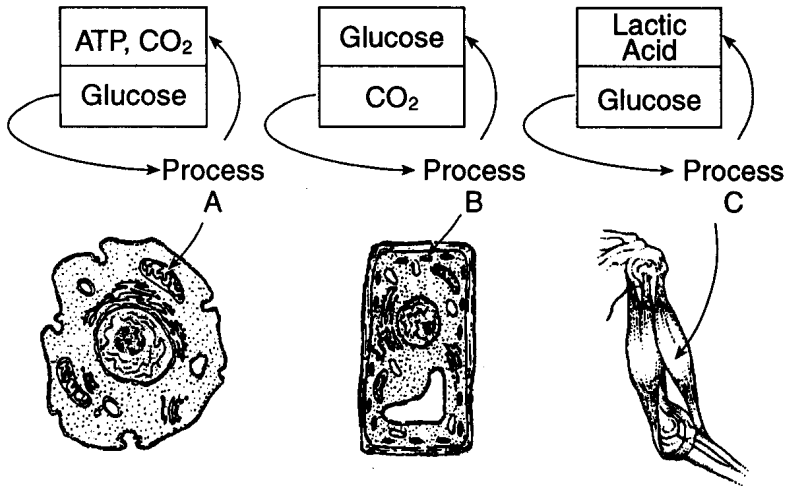

What is Process A called?

- A) photosynthesis
- B) fermentation
- C) dehydration synthesis
- D) aerobic respiration

21. If the test tubes represented in the diagrams below were allowed to stand at room temperature for several hours, which test tube would most likely contain the greatest amount of alcohol and carbon dioxide?

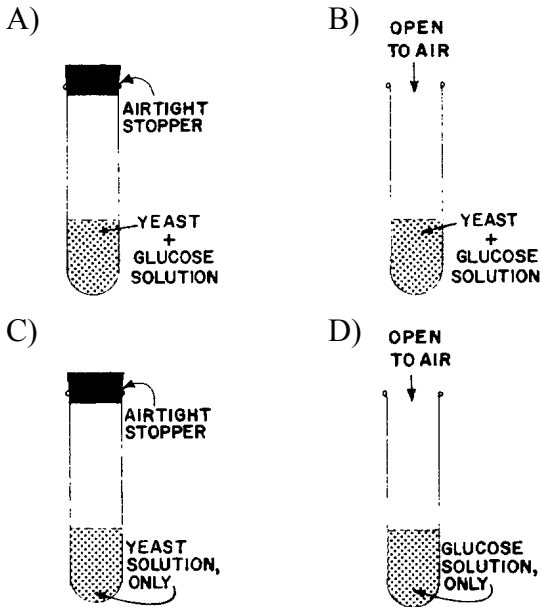

22. In what way are photosynthesis and cellular respiration similar?

- A) They both occur in chloroplasts.
- B) They both require sunlight.
- C) They both involve organic and inorganic molecules.
- D) They both require oxygen and carbon dioxide. inorganic produce

23. The graph below shows the number of push-ups a student completed in each of four 2-minute trials (A-D) during a 15-minute exercise period.

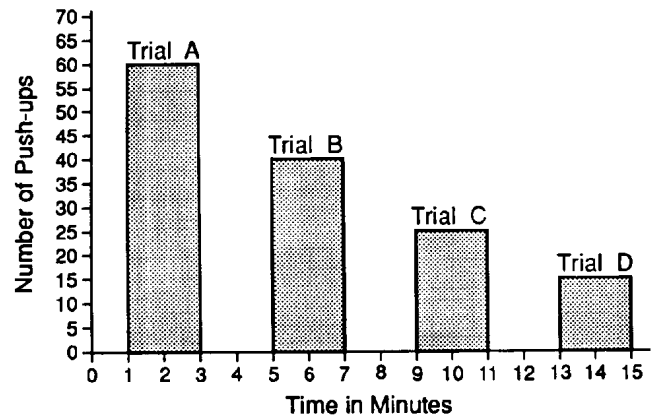

The concentration of lactic acid in the student's muscle tissue was most likely greatest during trial

- A) A
- B) B
- C) C
- D) D

24. How do guard cells of a leaf help to maintain homeostasis in a plant?

25. Base your answer to the following question on the summary equations of two processes below.

Photosynthesis

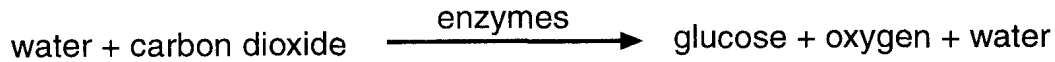

Respiration

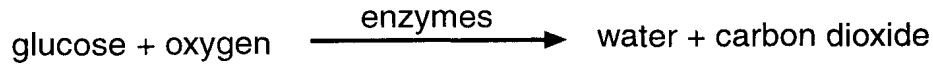

State *one* reason *each* of the two processes, Photosynthesis and Respiration, is important for living things.

26. Base your answer to the following question on the information and diagram below and on your knowledge of biology.

Two test tubes, *A* and *B*, were set up as shown in the diagram below. Bromthymol blue, which turns from blue to yellow in the presence of carbon dioxide, was added to the water at the bottom of each tube before the tubes were sealed. The tubes were maintained at the temperatures shown for six days. (Average room temperature is 20°C.)

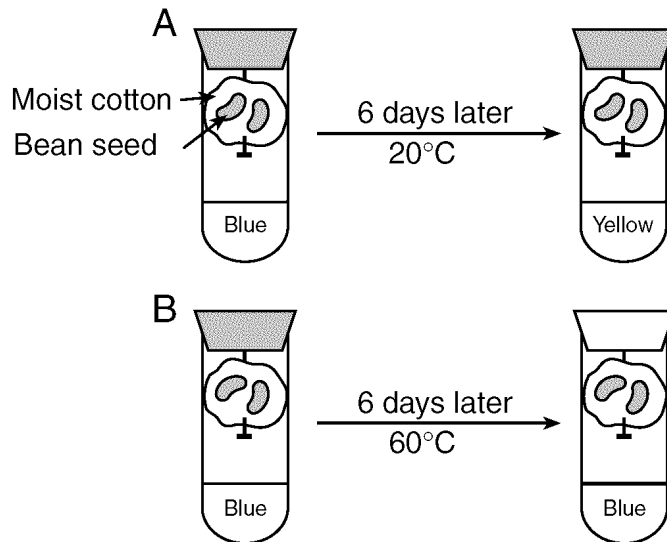

Identify the life process responsible for the change in tube *A*.

27. Base your answer to the following question on the information and diagram below.

The diagram represents a system in a space station that includes a tank containing algae. An astronaut from a spaceship boards the space station.

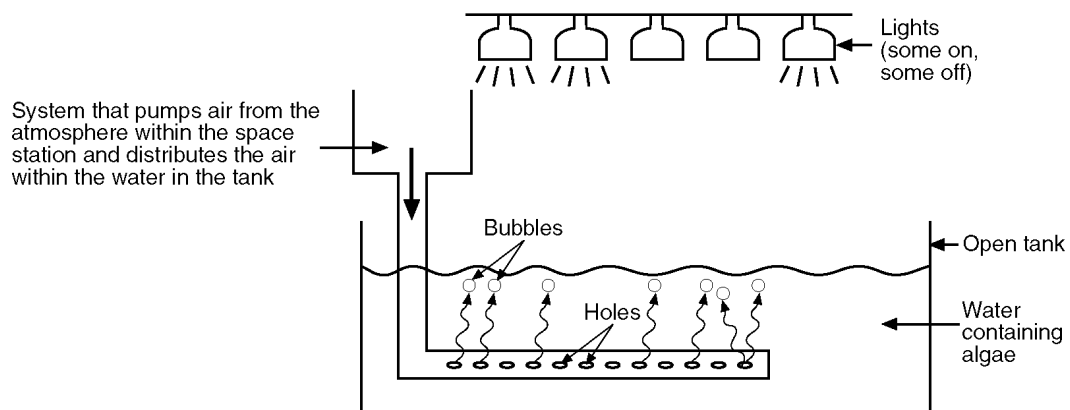

State *two* changes in the chemical composition of the space station atmosphere as a result of the astronaut coming on board the space station.

28. Base your answer to the following question on the information and graph below and on your knowledge of biology.

A student conducts an experiment to determine how the amount of light affects the rate of oxygen production in a plant. The graph represents the rate of oxygen produced for one trial, *X*, in the experiment. By the end of the experiment, the plant had not reached maximum oxygen production.

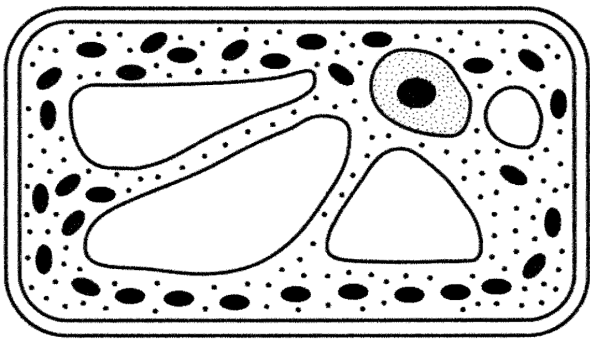
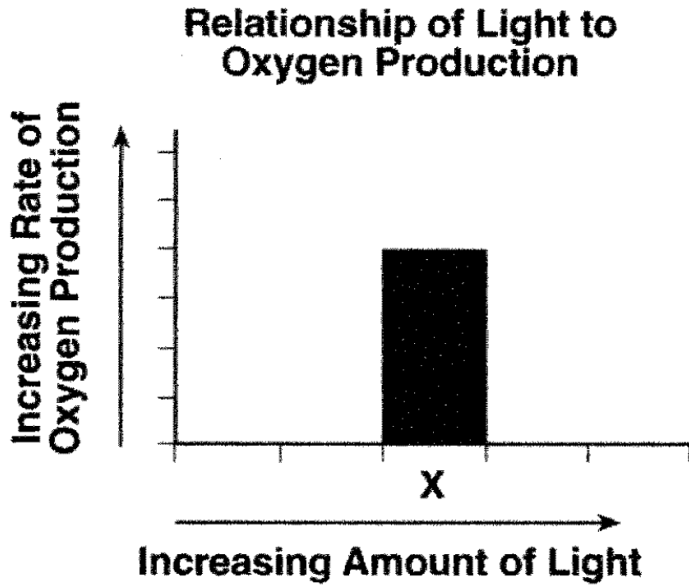

Identify the biochemical process occurring in this cell that produces the oxygen.

Process: _____

29. Base your answer to the following question on the information below and on your knowledge of biology

Yeast cells carry out the process of cellular respiration as shown in the equation below.

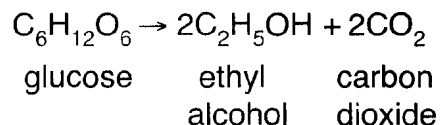

An investigation was carried out to determine the effect of temperature on the rate of cellular respiration in yeast. Five experimental groups, each containing five fermentation tubes, were set up. The fermentation tubes all contained the same amounts of water, glucose, and yeast. Each group of five tubes was placed in a water bath at a different temperature. After 30 minutes, the amount of gas produced (*D*) in each fermentation tube was measured in milliliters. The average for each group was calculated. A sample setup and the data collected are shown below.

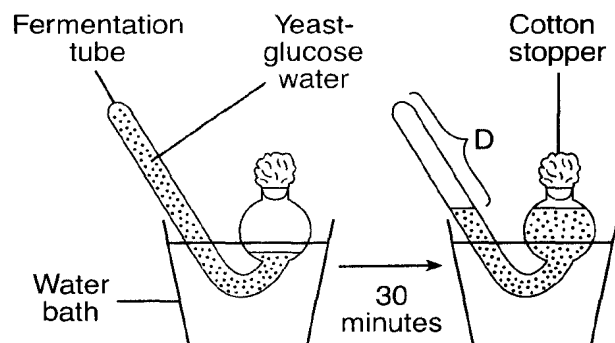

**Average Amount of Gas Produced (*D*)
After 30 Minutes at Various Temperatures**

| Group | Temperature (°C) | <i>D</i> (mL) |
|-------|------------------|---------------|
| 1 | 5 | 0 |
| 2 | 20 | 5 |
| 3 | 40 | 12 |
| 4 | 60 | 6 |
| 5 | 80 | 3 |

Average Amount of Gas Produced at Various Temperatures

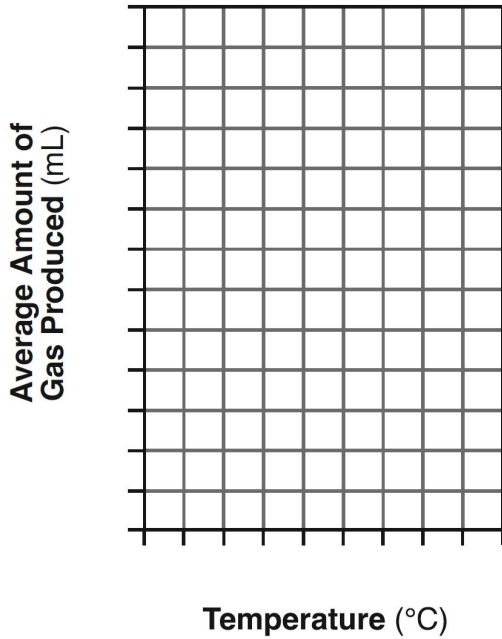

Compared to the other tubes at the end of 30 minutes, the tubes in group 3 contained the

- A) smallest amount of CO₂
- B) smallest amount of glucose
- C) smallest amount of ethyl alcohol
- D) same amounts of glucose, ethyl alcohol, and CO₂

30. Base your answer to the following question on the diagram below and on your knowledge of biology. The arrows in the diagram represent biological processes.

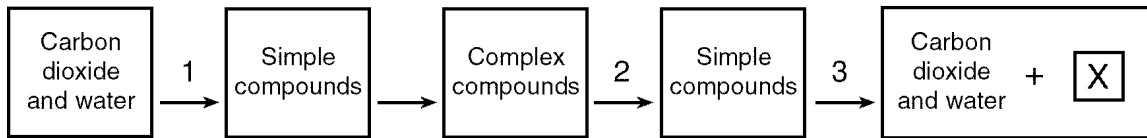

Identify what letter *X* represents.

31. Base your answer to the following question on the information below and on your knowledge of biology.

In an investigation, plants of the same species and the same initial height were exposed to a constant number of hours of light each day. The number of hours per day was different for each plant, but all other environmental factors were the same. At the conclusion of the investigation, the final height of each plant was measured. The following data were recorded:

8 hours, 25 cm; 4 hours, 12 cm; 2 hours, 5 cm; 14 hours, 35 cm; 12 hours, 35 cm; 10 hours, 34 cm; 6 hours, 18 cm

Data Table

| Daily Light Exposure (hours) | Final Height (cm) |
|------------------------------|-------------------|
| | |
| | |
| | |
| | |
| | |
| | |
| | |

Effect of Light Exposure on Plant Growth

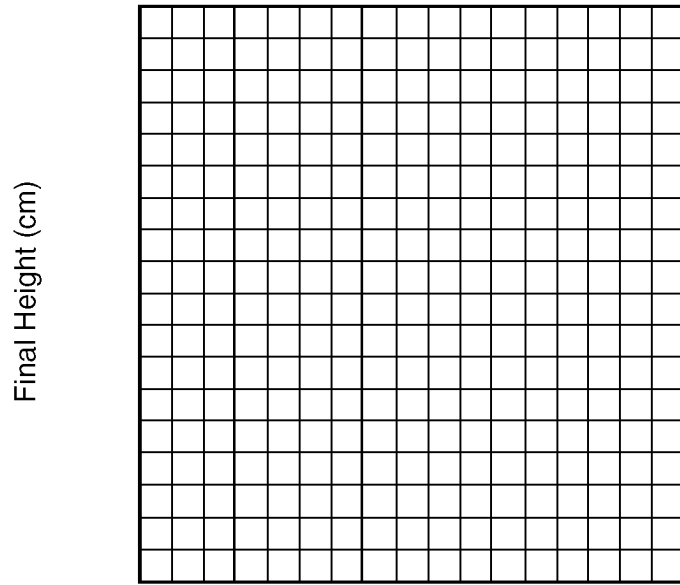

If another plant of the same species had been used in the investigation and exposed to 16 hours of light per day, what would the final height of the plant probably have been? Support your answer.

32. The data in the graph below show evidence of disease in the human body.

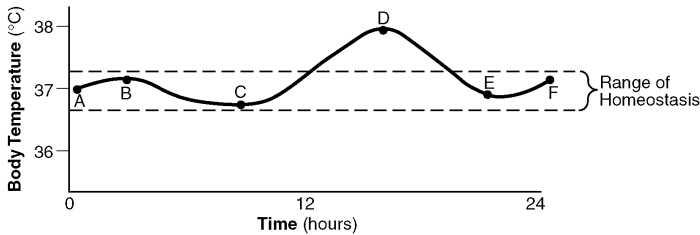

A disruption in dynamic equilibrium is indicated by the temperature change between points

- A) *A* and *B*
- B) *B* and *C*
- C) *C* and *D*
- D) *E* and *F*

33. Base your answer to the following question on the information and data table below and on your knowledge of biology.





In an investigation, three seeds of the same species were allowed to germinate and grow in three different locations. Each seedling was grown in the same amount and type of soil, and each received the same amount of water during a 6 day period. At the end of the investigation, the height of each seedling and the color of its leaves were recorded. The results are shown in the data table below.

| Data Table | | |
|-------------------|-------------|----------------|
| Location | Height (cm) | Leaf Color |
| Sunny windowsill | 7 | green |
| Indirect sunlight | 9 | green |
| Closed closet | 11 | whitish yellow |

Which statement correctly explains why chlorophyll production *decreased* in the seedlings kept in the closet?

- A) Lack of sunlight altered the expression of the gene for chlorophyll production.
- B) The enzymes involved in chlorophyll production mutate in cooler temperatures.
- C) Chloroplasts migrate to the center of the cell when light is not available.
- D) Chlorophyll is converted to another pigment when light is not present.

34. An experiment was performed to determine the effect of different mineral salts on plant growth. Forty pots containing genetically identical plants were divided into four equal groups and placed in a well-lighted greenhouse. Each pot contained an equal amount of nonmineral potting soil and one plant. Minerals were then added in equal amounts to each experimental group of pots as shown below.

| Control Group | Experimental Groups | | |
|---|---|---|---|
|  |  |  |  |
| | Water + Nitrogen salts | Water + Potassium salts | Water + Phosphorus salts |

For the experiment to be valid, what should be added to the control group of pots?

- A) water
- B) nitrogen salts
- C) potassium salts
- D) potassium and phosphorus salts

-
35. When a fish opens and closes its mouth, water is forced over the gills, which act as the sites of gas exchange. Four teams of students investigated the effect of temperature on the rate of mouth openings in a certain species of fish. Proper experimental procedure was followed throughout the investigation. The results are shown in the data table below.

Data Table

| | Number of Mouth Openings per Minute | | | |
|---------------------|--|-------------|-------------|-------------|
| TEAM | 30°C | 28°C | 26°C | 24°C |
| Team 1 | 105 | 105 | 103 | 102 |
| Team 2 | 109 | 105 | 103 | 101 |
| Team 3 | 112 | 105 | 102 | 96 |
| Team 4 | 104 | 103 | 103 | 100 |
| Team Average | 107.5 | 104.5 | 102.8 | 99.8 |

Using one or more complete sentences, predict what will most likely happen to the rate of respiration in this species of fish if the temperature is decreased to 22°C.

36. A small piece of black paper was folded in half and used to cover part of the top and bottom portions of a leaf on a living geranium plant. After the plant was kept in sunlight for several days, the paper was removed. The leaf was then boiled in alcohol to remove the chlorophyll and placed in Lugol's iodine solution, which turns blue-black in the presence of starch. Only the part of the leaf that had not been covered turned blue-black. This investigation was most likely testing the hypothesis that
- A) light is necessary for photosynthesis to occur
 - B) alcohol plus chlorophyll forms Lugol's iodine solution
 - C) green plants use carbon dioxide in photosynthesis
 - D) plants use alcohol in the production of chlorophyll
-

37. Base your answer to the following question on the diagram below, which is a concept map that shows the relationship between photosynthesis and respiration, and on your knowledge of biology.

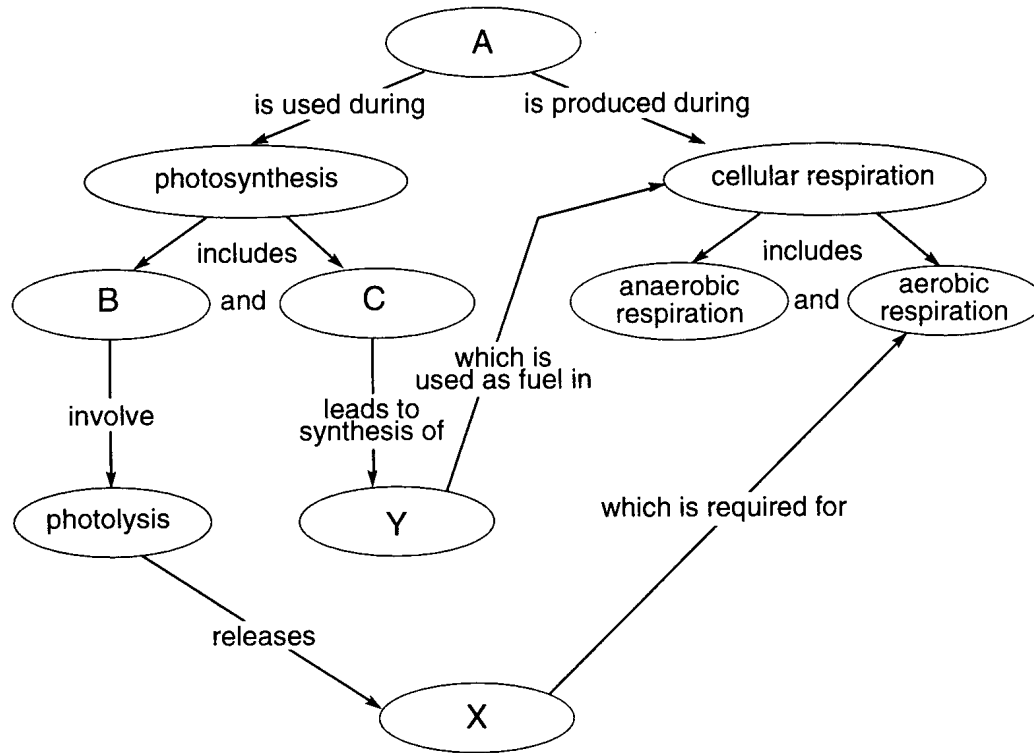

Which molecule belongs in area *A*?

- A) deoxyribonucleic acid
- B) adenosine triphosphate
- C) PGAL
- D) $C_6H_{12}O_6$

38. Base your answer to the following question on the information below and on your knowledge of biology.

A group of biology students extracted the photosynthetic pigments from spinach leaves using the solvent acetone. A spectrophotometer was used to measure the percent absorption of six different wavelengths of light by the extracted pigments. The wavelengths of light were measured in units known as nanometers (nm). One nanometer is equal to one-billionth of a meter. The following data were collected:

yellow light (585 nm) - 25.8% absorption
blue light (457 nm) - 49.8% absorption
orange light (616 nm) - 32.1% absorption
violet light (412 nm) - 49.8% absorption
red light (674 nm) - 41.0% absorption
green light (533 nm) - 17.8% absorption

| Color of Light | Wavelength of Light (nm) | Percent Absorption by Spinach Extract |
|----------------|--------------------------|---------------------------------------|
| | | |
| | | |
| | | |
| | | |
| | | |
| | | |

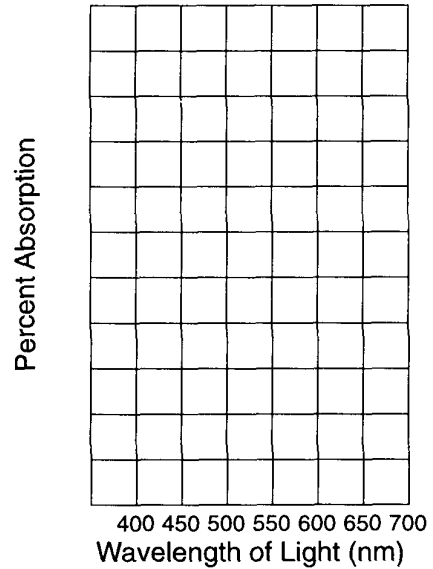

Which statement is a valid conclusion that can be drawn from the data obtained in this investigation?

- A) Photosynthetic pigments in spinach plants absorb blue and violet light more efficiently than red light.
- B) The data would be the same for all pigments in spinach plants.
- C) Green and yellow light are not absorbed by spinach plants.
- D) All plants are efficient at absorbing violet and red light.

39. Base your answer to the following question on the information and diagrams below and on your knowledge of biology.

In an investigation of the cycling of environmental gases, a student placed water and bromthymol blue in each of four test tubes as shown in the diagrams below. No additional items were placed in tube 1, a snail was placed in tube 2, an aquatic plant (elodea) was placed in tube 3, and both a snail and an elodea were placed in tube 4. The tubes were then stoppered and placed in bright light for 24 hours.

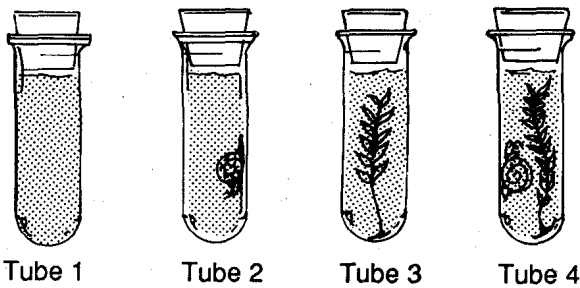

How would the solution in tube 3 change after 24 hours?

- A) It would contain more oxygen.
- B) It would change from blue to yellow.
- C) It would change from blue to brick red.
- D) It would contain less nitrogen.

40. A biological process that occurs in both plants and animals is shown below.

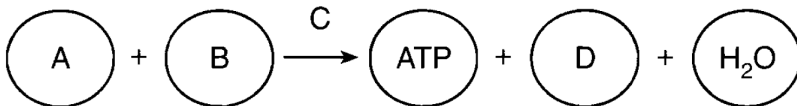

Which row in the chart below identifies the lettered substances in this process?

| Row | A | B | C | D |
|-----|----------------|-----------------|-----------------|-----------------|
| (1) | O ₂ | CO ₂ | glucose | enzymes |
| (2) | glucose | O ₂ | enzymes | CO ₂ |
| (3) | enzymes | O ₂ | CO ₂ | glucose |
| (4) | glucose | CO ₂ | enzymes | O ₂ |

- A) 1
- B) 2
- C) 3
- D) 4

41. In the cells of the human body, oxygen molecules are used directly in a process that

- A) releases energy
- B) digests fats
- C) synthesizes carbohydrate molecules
- D) alters the genetic traits of the cell

42. A biological process that occurs in plants is represented below.

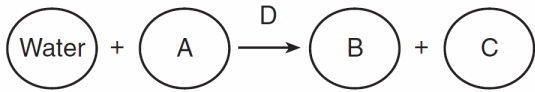

Which row in the chart below identifies the lettered substances in this process?

| Row | A | B | C | D |
|-----|----------------|---------|----------------|----------------|
| (1) | enzymes | oxygen | carbon dioxide | glucose |
| (2) | carbon dioxide | glucose | oxygen | enzymes |
| (3) | glucose | enzymes | oxygen | carbon dioxide |
| (4) | oxygen | glucose | carbon dioxide | enzymes |

- A) (1) B) (2) C) (3) D) (4)

43. The diagram below represents a plant cell.

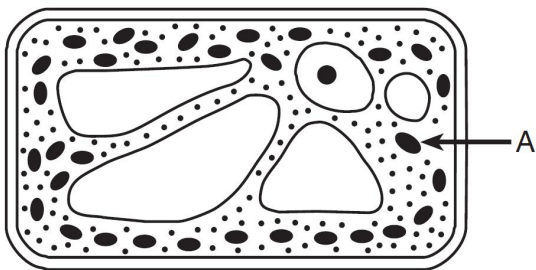

For the process of photosynthesis, the arrow labeled A would most likely represent the direction of movement of

- A) carbon dioxide, water, and solar energy
- B) oxygen, sugar, and solar energy
- C) carbon dioxide, oxygen, and heat energy
- D) sugar, water, and heat energy

44. In the transfer of energy from the Sun to ecosystems, which molecule is one of the first to store this energy?

- A) protein
- B) fat
- C) DNA
- D) glucose